



Collection: DTV PROMPT

Finish*:



Main features:



Features

- **Dimensions:** 197 x 68 x 19
- **Installation:** Built-in
- **Countdown mode:** the duration of the shower is set to manage water use
- **Temperature control** guarantees safe use
- **Versatile:** the integrated diverter lets you toggle between water outlets or run them simultaneously
- **Weight:** 0.9 kg
- **Warm-up mode:** once the desired temperature is reached, the water pauses until you enter the shower
- **Pause:** this feature lets you pause water flow for 2 minutes
- **User-friendly** and easy to use, thanks to the large LCD display and three buttons
- **Easy to install:** Interface connecting to the thermostatic valve by a standard phone cord, integrated transformer, valve connecting to the power supply

Technical drawing

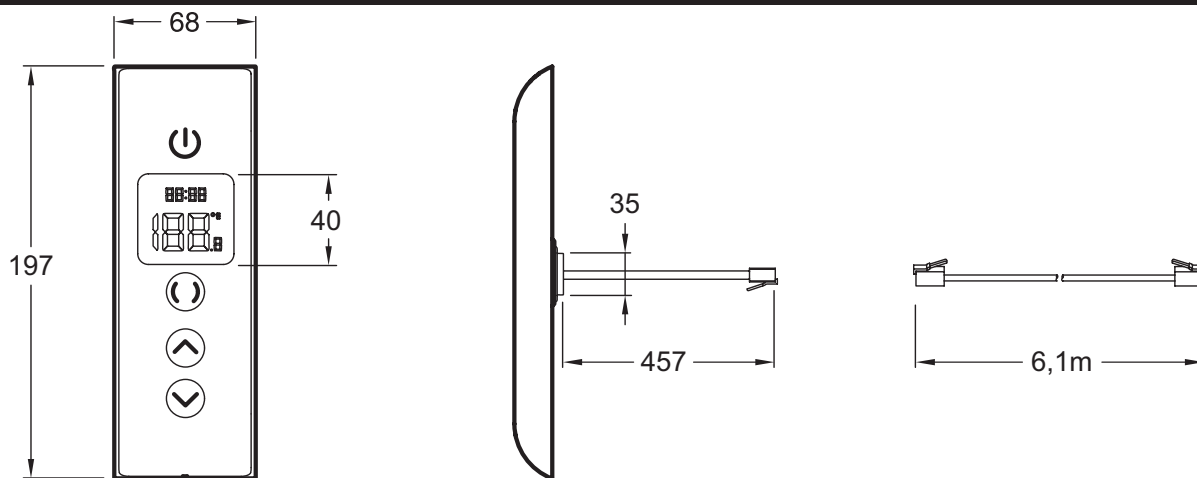

Product Specification: Digital Interface. 527D. Collection: DTV PROMPT. Dimensions: 197 x 68 x 19. Weight: 0.9 kg. Installation: Built-in. Warm-up mode: once the desired temperature is reached, the water pauses until you enter the shower. Countdown mode: the duration of the shower is set to manage water use. Pause: this feature lets you pause water flow for 2 minutes. Temperature control guarantees safe use. User-friendly and easy to use, thanks to the large LCD display and three buttons. Versatile: the integrated diverter lets you toggle between water outlets or run them simultaneously. Easy to install: Interface connecting to the thermostatic valve by a standard phone cord, integrated transformer, valve connecting to the power supply.