

### Tall single-lever washbasin mixer 16231D-4



**Collection:** MARGAUX

**Finish\*:**



CP - Polished  
Chrome

**Main features:**



#### Features

- Weight: 3.3 kg
- Flow rate: 8 l/min
- Mechanism: Ceramic Joystick disc cartridge
- Joystick lever
- No lift rod
- Installation: 1 hole
- Connection: With supply hoses
- Margaux offers a unique blend of traditional design elements and modern fluidity to complement eclectic design interiors with refreshed sophistication
- Anti-scale aerator

#### Technical drawing

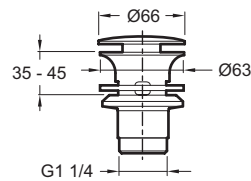
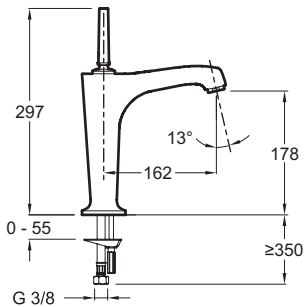

Product Specification: Tall single-lever washbasin mixer. 16231D-4. Collection: MARGAUX. Weight: 3.3 kg. Installation: 1 hole. Flow rate: 8 l/min. Connection: With supply hoses. Mechanism: Ceramic Joystick disc cartridge. Margaux offers a unique blend of traditional design elements and modern fluidity to complement eclectic design interiors with refreshed sophistication. Joystick lever. Anti-scale aerator. No lift rod.