

Tall single-lever basin mixer 10379D



Collection: OBL0

Finish*:



CP - Polished Chrome

Main features:



Features

- Weight: 2.9 kg
- Flow rate: 8 l/min
- Mechanism: Sequential cartridge
- Integrated anti-scale aerator
- Installation: 1 hole
- Connection: With supply hoses
- The simple, ergonomic design offers a sleek, modern appeal with a European influence
- With sequential cartridge

Technical drawing

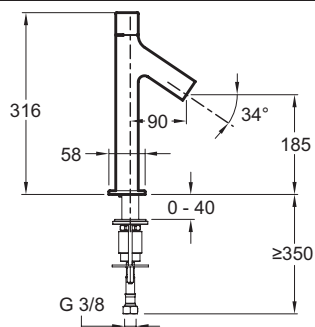

Product Specification: Tall single-lever basin mixer, 10379D. Collection: OBL0. Weight: 2.9 kg. Installation: 1 hole. Flow rate: 8 l/min. Connection: With supply hoses. Mechanism: Sequential cartridge. The simple, ergonomic design offers a sleek, modern appeal with a European influence. Integrated anti-scale aerator. With sequential cartridge.