

### Tall single-lever washbasin mixer 985D-4



**Collection:** STILLNESS

**Finish\*:**



CP - Polished  
Chrome

**Main features:**



### Features

- Weight: 2 kg
- Flow rate: 6 l/min
- Mechanism: Sequential cartridge
- Anti-scale system
- Installation: 1 hole
- Connection: With supply hoses
- Streamlined element, pure design and industrial integrity lend aesthetic functionality to minimal spaces
- No lift rod

### Technical drawing

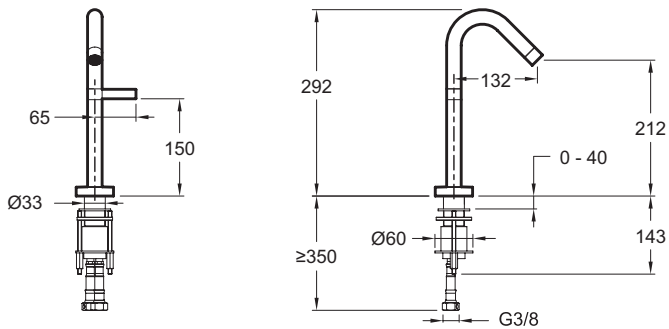

Product Specification: Tall single-lever washbasin mixer. 985D-4. Collection: STILLNESS. Weight: 2 kg. Installation: 1 hole. Flow rate: 6 l/min. Connection: With supply hoses. Mechanism: Sequential cartridge. Streamlined element, pure design and industrial integrity lend aesthetic functionality to minimal spaces. Anti-scale system. No lift rod.