

Whirlpool bath, Excellence system, right handed, 180 x 80 cm 5BD214R



Collection: EVOK

Finish*:



00 - White

Consumer benefits

• **SILENCE:** All our systems are equipped with the Silence gentle-massage program that was specially designed to be quiet

• **DESIGN AND PERFORMANCE:** Waterfall headrest ; Water massage (back, side and foot jets fit flush) ; Air massage (invisible air injectors at the bottom) ; Chromotherapy ; Backlit keypad

Features

- Dimensions: 200 x 100
- Installation: Built-in
- **Massages type:** 4 Massage programs (Silence, Tonic, Wave and Relax): water massage, turbo massage, air massage, draining massage
- **Injectors:** Body massage: 18 air injectors
- **Safety system:** Safety feature (no water)
- 1 LED spotlight
- Cleaning cycle
- Pump 900 W
- Air blower with water heater and ozone 1000 W

- **Material:** Acrylic
- **Volume:** 260
- **Jets:** Back massage: 4 mini-jets ; Foot massage: 2 rotating jets ; Body massage: 6 rotating jets, 4 mini jets
- **Chromotherapy:** Yes
- 5-button keypad
- Automatic ozone drying and sanitizing cycle
- Noise/vibration reduction Soundproofing kit & Silence box
- Turbo blower with water heater 1000 W
- Self-supporting frame

Required products

- E6D015: Doble pop-up drain and overflow
- 70174K: Standard waste

Optional products

- E6757: Small neck support oval
- E6965: Neck support
- E6T21: Side panel
- E6T24: Side panel
- E6T38: Front panel 180 x 80 cm
- E6T36: Side panel 80 cm

Technical drawing

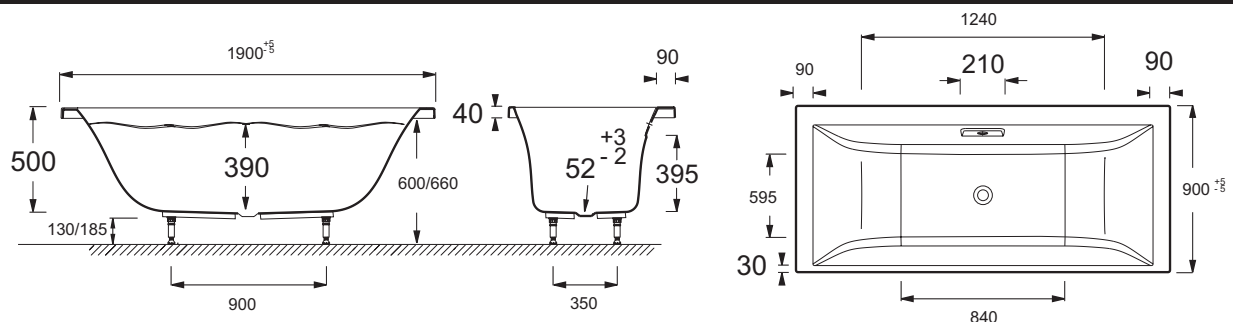

Product Specification: Whirlpool bath, Excellence system, right handed, 180 x 80 cm. 5BD214R. Collection: EVOK. Dimensions: 200 x 100. Material: Acrylic. Installation: Built-in. Volume: 260. Massages type: 4 Massage programs (Silence, Tonic, Wave and Relax): water massage, turbo massage, air massage, draining massage. Jets: Back massage: 4 mini-jets ; Foot massage: 2 rotating jets ; Body massage: 6 rotating jets, 4 mini jets. Injectors: Body massage: 18 air injectors. Chromotherapy: Yes. Safety system: Safety feature (no water). 5-button keypad. 1 LED spotlight. Automatic ozone drying and sanitizing cycle. Cleaning cycle. Noise/vibration reduction Soundproofing kit & Silence box. Pump 900 W. Turbo blower with water heater 1000 W. Air blower with water heater and ozone 1000 W. Self-supporting frame.