

Tall 2-handle 3-hole basin mixer 10094D



Collection: OBLO

Finish*:



CP - Polished
Chrome

Main features:



Features

- Weight: 3.2 kg
- Flow rate: 6 l/min
- The simple, ergonomic design offers a sleek, modern appeal with a European influence
- Fixed spout separated from handles on plate
- Installation: 3 holes
- Mechanism: Ceramic disc heads
- Integrated anti-scale aerator
- Rectangle plate: 158 mm x 58 mm

Technical drawing

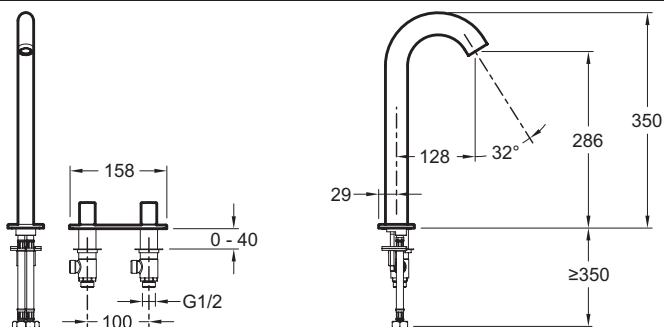

Product Specification: Tall 2-handle 3-hole basin mixer. 10094D. Collection: OBLO. Weight: 3.2 kg. Installation: 3 holes. Flow rate: 6 l/min. Mechanism: Ceramic disc heads. The simple, ergonomic design offers a sleek, modern appeal with a European influence. Integrated anti-scale aerator. Fixed spout separated from handles on plate. Rectangle plate: 158 mm x 58 mm.